

# 35N

# IHI

COMPACT EXCAVATOR SALES LLC

400 Production Court  
Elizabethtown, KY 42701  
Phone: 800.538.1447 Fax: 270.737.0419  
www.ihices.com



**Full-opening cover.**

The engine cover and right side cover can easily be fully opened.



**Larger engine adopted.**

Engine compliant for EC Stage IIIA and EPA Interim Tier4.



**Accumulator**

The accumulator is installed to depressurize auxiliary line and lower attachments in emergency.



**Large Traction pedals**

The large traction pedals are equipped as standard.

### Eco-friendliness and Safety

- Engine compliant for EC Stage IIIA and EPA Tier4.
- Conform to the EC low noise regulation.
- Swing parking brake equipped as standard.
- The accumulator is installed as to depressurize auxiliary line and lower attachments in emergency.

### Easy Operation

- Joystick lever control enables precision operation.
- Largest operation space in its class.
- A large backfill blade makes backfilling easier and offers high durability.
- Travel speed selector switches equipped in two locations. (On backfill lever and the left console box.)
- The foot space extended. (10% wider than N2.)

### Easy Maintenance

- Sintering metal bush extends greasing interval.
- Aluminum radiator and oil cooler resist rusting.
- Segmented boom cylinder hoses for easier replacement.
- Full-opening engine cover for easy maintenance.
- The radiator protective net is equipped as standard.

### Rugged Body

- Embedded boom lamp to prevent damage.
- The engine cover and the side cover are pressed steel and very rugged.
- Bucket cylinder hoses are placed inside the arm.
- Cast Iron large side guard and counterweight.
- Arm link pin fixed by castle nut.

## ■ Dimensions

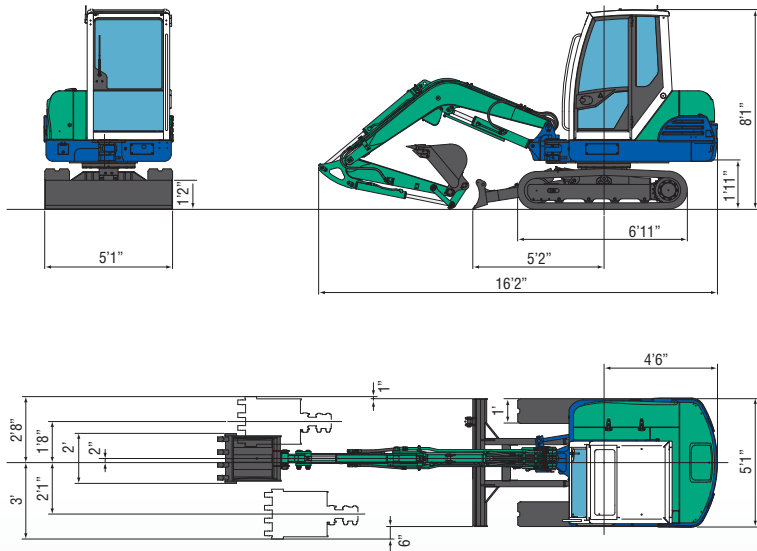

## ■ Working Range

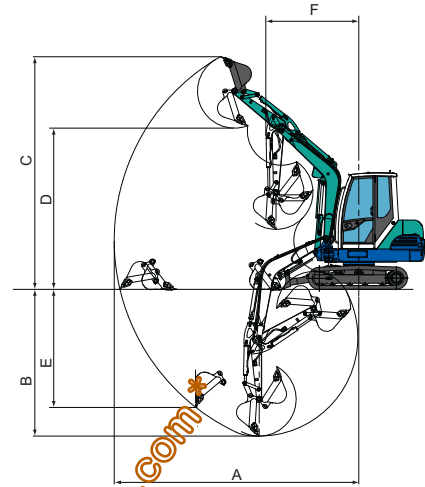

	Cabin
A Max. swing radius	16'8"
B Max. digging depth	10'4"
C Max. digging height	16'2"
D Max. dumping height	11'
E Max. vertical digging depth	8'
F Min. front turning radius	6'4"
At right boom swing	5'



# 35N

## Mini Excavator

Standard Bucket Capacity: ISO 3.9 cu. ft.

*Outstanding Stability, Robust Design.  
3.5 metric ton Conventional Type Mini.*

## ■ 35N3 Specifications

Model	35N3
• Performance	
Bucket capacity	3.9 cuft
Bucket width	24"
Operating weight : Cabin (4 post)	7979 lbs (7759 lbs)
Transportation weight : Cabin (4 post)	7439 lbs (7219 lbs)
Swing speed	10 mph
Travel speed (low/high)	1.7/3 mph
Gradeability	30°
Ground pressure	4.1 psi
Max.bucket digging force	7662 lbs
• Engine	
Model	YANMAR 3TNV88
Rated output	26.7 hp/2300 rpm
Fuel tank capacity	13 gal
• Boom swing system	
Type	Boom offset with hydraulic cylinder
Swing angle (L/R)	50° / 90°
• Hydraulic system	
Pressure	2987 psi
Pump hydraulic flow	10.6 gal/ min x2 + 6.5 gal/ min
Type Piston / Gear	2 Piston / 2 Gear
Auxiliary Flow	16.7 gal
• Backfill blade	
Size	61" x 14"
Lift above ground / Drop below ground	15"/ 18"



4 Post Canopy

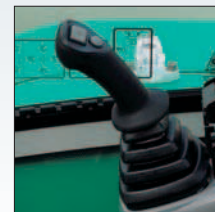

Proportional Control Valve

## ■ Options

• Bucket
12"
18"
24"
36"
48" Ditch Cleaning Bucket
48" Hydraulic Swivel Bucket
• Steel Tracks
• Steel Cab
• Hydraulic Thumb
• Quick Coupler