

40VXL



400 Production Court
 Elizabethtown, KY 42701
 Phone: 800.538.1447 Fax: 270.737.0419
 www.ihices.com



* Heavy and Construction Equipment * (800) 665-2818 * hceweb.com *



New environmentally friendly engine.

Clean engine compliant for EC Stage IIIA and EPA Interim Tier4.



Close distance between bucket and backfill blade.

By optimizing attachment geometry, digging performance near the backfill blade has been improved.



Comfortable operating environment.

Largest operator's space in its class.

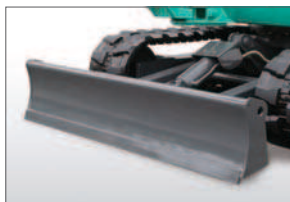

Large backfill blade.

A large backfill blade makes backfilling easier and offers high durability.

Eco-friendliness and Safety

- Engine compliant for EC Stage IIIA and EPA Tier4.
- Conform to the EC low noise regulation.
- 4 post canopy (ROPS&TOPS) equipped as standard.
- Swing parking brake equipped as standard.

Easy Operation

- Joystick lever control enables precision operation.
- Largest operation space in its class.
- A large backfill blade makes backfilling easier and offers high durability.
- Offset positioned boom to ensure wide view in front.

Easy Maintenance

- Aluminum made radiator and oil cooler resist rusting.
- Wide engine cover for easy maintenance.
- Segmented boom cylinder hoses for easier replacement.

Rugged Body

- Embedded boom lamp to prevent damage.
- The engine cover and the side cover are rugged pressed steel.
- Bucket cylinder hoses are placed inside of arm.
- Equipped with rugged backfill blade.

■ Dimensions

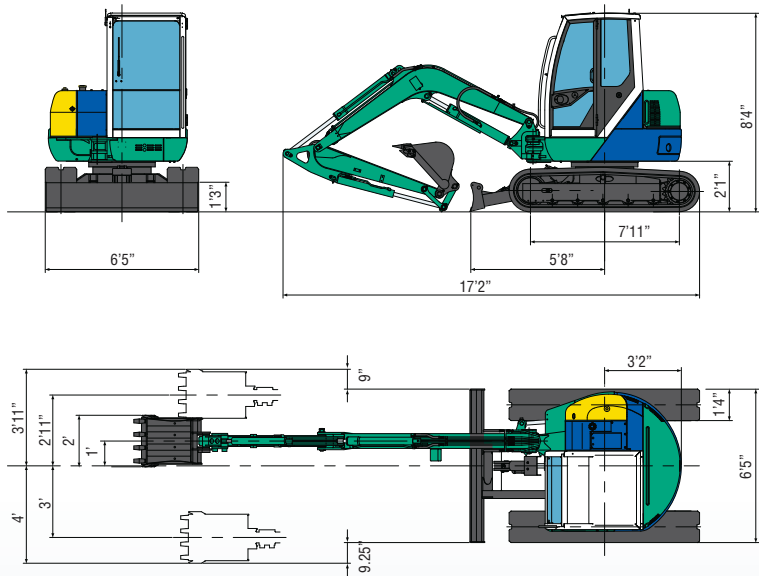

■ Working Range

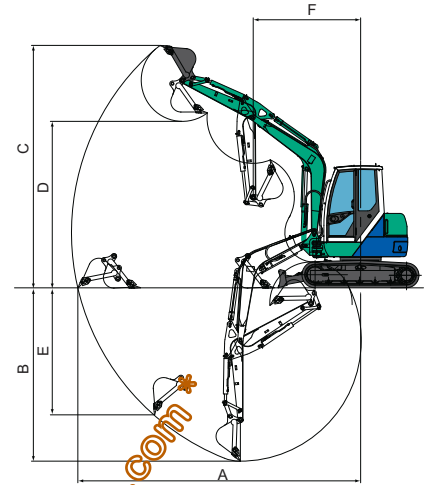

	Cabin	4post
A Max. digging reach	19'1"	19'1"
B Max. digging depth	11'2"	11'2"
C Max. digging height	16'7"	17'5"
D Max. digging height	11'3"	12'
E Max. vertical digging depth	11'9"	11'9"
* Min. front turning radius	8'4"	7'9"
At right boom swing	7'3"	6'7"



40VXL

Mini Excavator

Standard Bucket Capacity: ISO 4.6 cu. ft.

**Powerful and Compact 4.4 metric ton.
Superior Transportability and Power.**

■ 40VXL Specifications

Model	40VXL
• Performance	
Bucket capacity	4.6 cuft
Bucket width	24"
Operating weight : Cabin (4post)	10206 lbs (9919 lbs)
Transportation weight : Cabin (4post)	10041 lbs (9754 lbs)
Swing speed	8.9 mph
Travel speed (low/high)	1.9 mph/ 3.2 mph
Gradeability	30°
Ground pressure	3.6 psi
Max.bucket digging force	9854 lbs
• Engine	
Model	YANMAR 4TNV88
Rated output	37.1 hp/ 2400rpm
Fuel tank capacity	17.2 gal
• Boom swing system	
Type	Boom offset with hydraulic cylinder
Swing angle (L/R)	50° / 90°
• Hydraulic system	
Pressure	3000 psi
Pump hydraulic flow	15.9 gal/ min × 2 + 11.6 gal/ min
Type-Piston / Gear	2 Piston + 2 Gear
Auxiliary Flow	18.5 gal
• Backfill blade	
Size	76.8" × 14.6"
Lift above ground / Drop below ground	16.1" / 14.2"



4 Post Canopy



Steel Shoe

■ Options

• Buckets
12"
18"
24"
36"
48" Ditch Cleaning Bucket
48" Hydraulic Swivel Bucket
• Steel Cabin
• Steel Tracks
• Hydraulic Thumb
• Quick Coupler